



LN-QE-B50
QUANTUM ELITE™ 4K
Day/Night Vision Binoculars 6-36x50



Instruction Manual



QUANTUM ELITE™ Day/Night Vision Binoculars represent the highest level of digital electro-optics technology featuring an ultra-light sensitive large format CMOS sensor allowing it to be used in near dark conditions without the aid of a built-in IR illuminator. This device can be safely used in both daytime and nighttime. It features dual IR illuminators: 850nm and 940nm to aid viewing in completely dark conditions. The image is transferred from the CMOS sensor onto the two AMOLED HD displays. This binocular can record videos with up to 4K resolution and it can take 16.1MP still photos. A fully integrated laser rangefinder function provides accurate distance measurement with a range up to 1500m/1635yds. Whether you are interested in exploring nature, hunting, sky-watching, bird and wildlife observation, or property management and home security, this digital day/night vision binocular is your perfect 24/7 companion.

WARNING:

Please comply with the following basic safety requirements when using this electro-optical device.

- This device is for adult users only. Children must be supervised by an adult while using this device.
- This device is not a toy, please treat and use it carefully, as you would normally have a high quality digital photo/video camera.
- Please know and observe your local laws and regulations regarding the use of night vision devices.

Maintenance:

Keep away from moisture and store it in a cool and dry place. Do not try to repair the product by yourself. Users can clean the lens with a dry and soft wiping cloth.

Product Glossary:

1. Infrared light (850nm)
2. Distance focusing wheel
3. Infrared light (940nm)
4. Laser rangefinder
5. Protective lens covers
6. Distance measurement button
7. Photo/video recording button
8. Power/IR illuminator button
9. Left eyepiece adjustment wheel
10. Power on indicator
11. Eyepieces/displays
12. Right eyepiece adjustment wheel
13. Connectivity area cover
14. USB-C power connector
15. Micro-SD card slot
16. HDMI output
17. Battery cover
18. ¼" tripod connector

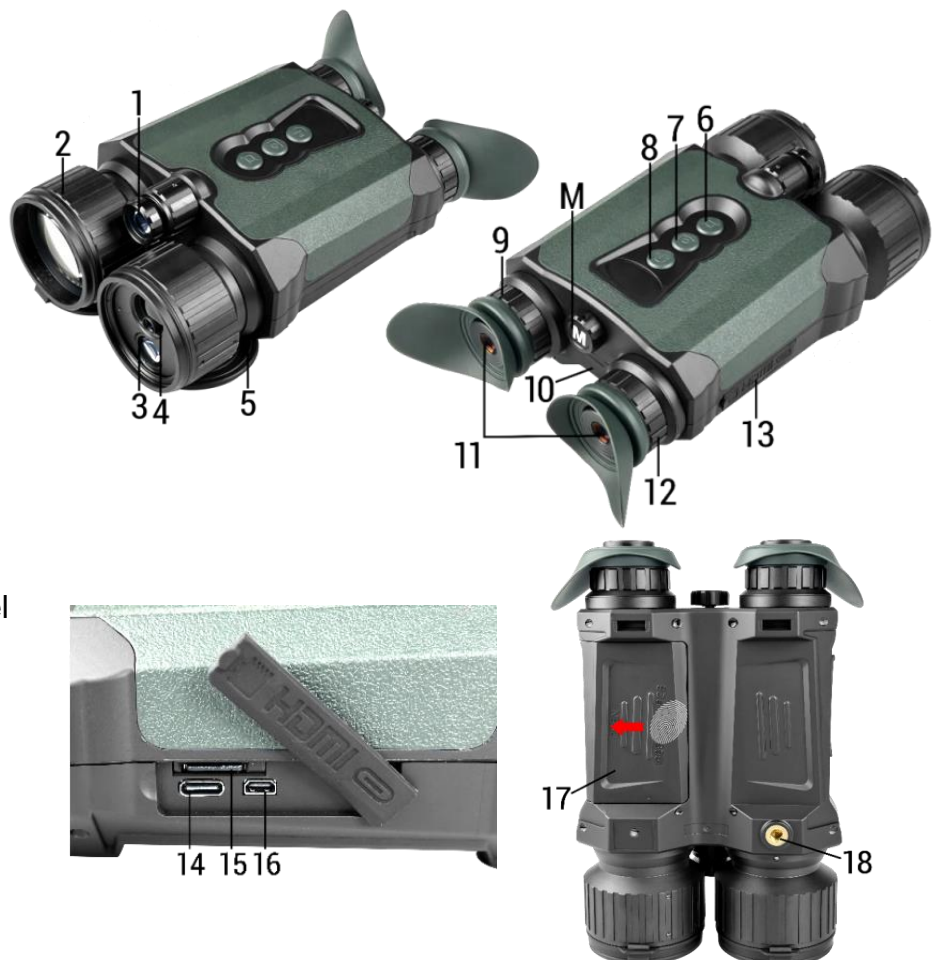

M. Multi-function Controller

Image Display Icons



1. Video recording indicator and timer
2. Taking photo while recording video
3. Image color selection
4. Ultra night vision mode
5. Display brightness adjustment
6. Video recording mode
7. Ultra night vision mode is on
8. Current image magnification
9. Date, time
10. Horizontal angle
11. Electronic image stabilizer mode is on
12. Infrared illuminator power level
13. Battery condition
14. Laser rangefinder distance data and box
15. Elevation angle / depression angle
16. 360° azimuth angle

Battery installation / power supply choice

There are several different ways to supply power to the device. Users should buy the regular 18650 batteries with 67mm length, and the battery positive pole must have a protrusion. Other batteries cannot be used in this product.

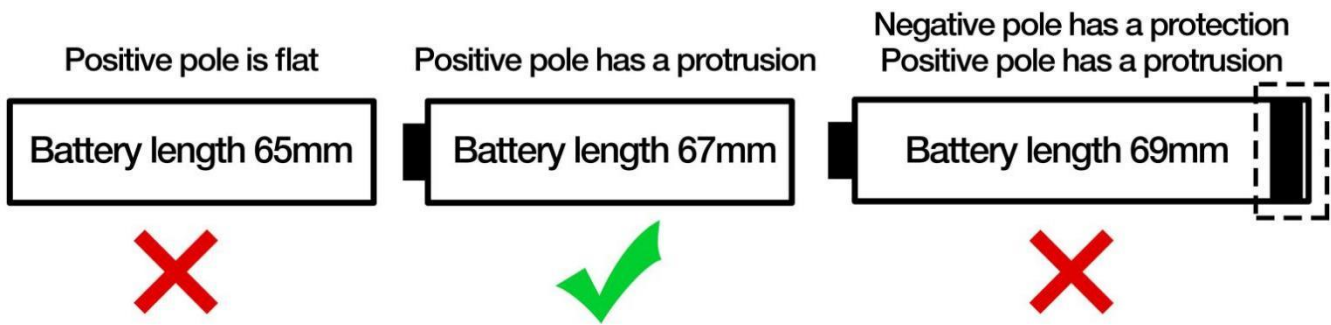

1, To install the batteries, see the above vertical picture of the bottom of the binocular. Slightly press the thumb icon on the battery cover (17) with thumb, and at the same time, slide the battery cover according to the arrow direction. Now the battery container is open. Then place the woven tape at the bottom of the battery container, and install four 18650 batteries (battery length 67mm, positive pole has a protrusion) in the battery container. Pay attention to the icons of the battery positive pole and negative pole positions on battery container. Finally, adjust the woven tape position and install the battery cover on battery container. If installed correctly, you should be able to remove the batteries by gently pulling out the woven tape.

2, In order to reduce overall binocular weight, or, when operating from 5V power bank, you can choose to install only two 18650 batteries into the bottom part of the battery container according to the positive and negative pole icons. Then, put the included sponge pad on the two batteries as a filling, the sponge pad is one of the accessories. Finally, adjust the woven tape position and install the battery cover on battery container.

3, By power bank: connect a 5V2A power bank connected to the USB-C port (14).

Attention:

1, When installing batteries, the direction of battery positive pole and negative pole must be correct. If the battery direction is wrong, the device will not operate.

2, The voltage of the external power bank cannot exceed 5V. Otherwise, it will burn out the device circuit system and void any warranty claims.

3, To ensure a longer lifespan of the device, the internal USB-C port cannot charge the batteries inside the device. The 18650 batteries need to be charged in an external charger.

Power On / Off

To start the device, press and hold the power button (8) for 2 seconds.

The power on indicator (10) will turn bright green.

On the screen, you can briefly see the word "Welcome" through the eyepieces (11).



To shut down the device, press and hold the power button (8) for 3 seconds.

On the screen, users can see a progress bar powering off. Do not let go of the power button until the image completely disappears from the screen, indicating the device is off.

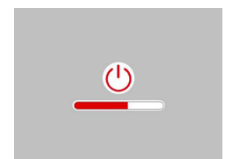

Focusing the eyepieces and objective lens

Remove both protective lens covers (5). After turning on the device, users can see the image through two eyepieces (11). Rotate the two eyepiece adjustment wheels (9) and (12) individually and focus on the icons and words on the image displays. Next, adjust the distance between two eyepieces by

sliding the eyepieces either towards or away from each other. When icons and words are sharp and clear on screen and image appears as one single display, you have completed focusing the eyepieces well.



Adjustable Range: 60-71mm

Now rotate the distance focusing lens (2) until the objects you are viewing are sharp and clear. After this adjustment is complete, you would generally only need to focus the distance wheel (2) going forward.

Focusing Tips:

Many users have different eye vision. If your eyes feel uncomfortable or the image is not clear enough during observation, it may be caused by incorrect eyepiece focusing or incorrect distance between left and right eyepieces. You can focus the two eyepieces again and adjust the distance of two eyepieces again according to the above methods. You can also close one eye while adjusting the second eye. Ensure that your eyes can see the clearest image of icons and words on the display screen before using this device to observe objects at a distance.

How to see in the dark

Users can choose between 850nm infrared light and 940nm infrared light wavelength. 850nm light will extend the effective viewing distance, however it emits a faint red glow and can be detected by an animal or even a human if looked directly into the IR lens (1). 940nm light will operate over a shorter distance, however it is almost completely invisible, even to the animal eyes and will allow for more covert operation in the dark. Press and hold the Multi Controller (M) for 2 seconds to enter the main menu. Rotate the controller to select the IR Switching menu. Short press controller to enter 850NM / 940NM. Rotate controller to select the desired infrared light wavelength, then short press again to turn on the infrared light. Press and hold controller for 2 seconds to exit the menu.

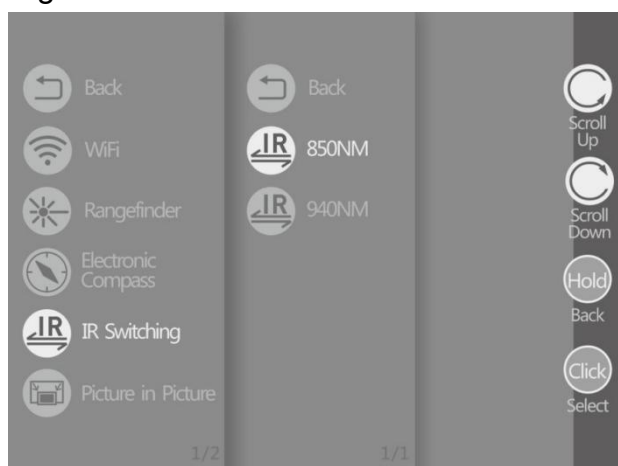

Tips for Multi-Controller (M) (Multi-function Controller):

- 1, During observation, rotating controller (M) clockwise will increase image magnification and rotating it counterclockwise will reduce the image magnification.
 - 2, Short press controller (M) to show quick sub-menu. There, when rotating (M) onto the function, the sub-menu of that menu will be shown automatically.
 - 3, Press and hold the controller (M) for 2 seconds to enter the main menu. Rotate controller (M) to scroll to any desired menu function in main menu. Short press controller (M) to enter and then activate the menu function. Press and hold the controller (M) for 2 seconds to enter the previous menu or exit the main menu.
-

Turning on the 850nm infrared light (same procedure when 940nm IR light is selected):

Press Power/IR Illuminator button (8) momentarily. The icon  will be shown on bottom right of the screen. It means the 850nm infrared light is turned on and the IR brightness is on level 1.

Press button (8) momentarily again. The icon  will be shown. It means the IR brightness is on level 2.

Press button (8) once again, the icon  will be shown. It means the IR brightness is on level 3. Press button (8) once again and the infrared light will be turned off. You can circularly adjust the infrared light brightness among these 3 levels.

When the infrared light (1) is turned on, you can rotate the IR lens (1) to adjust the width of the IR beam. When the IR beam is focused/narrowed, you will see smaller illuminated area, but further in the dark, when the beam is widened, you will see wider illumination, but over a shorter distance.

WARNING: Class-3R laser product

When infrared light is turned on, do not look directly into the infrared light beam lens (1) or (3).

Staring into the infrared beam for a long time may damage your eyes.



QUICK SUB-MENU: Ultra Night Vision Mode / display brightness / image color

If you wish to keep the IR light off in dark conditions, you may utilize Ultra Night Vision Mode. Press controller (M) momentarily to enter the quick sub-menu , rotate controller (M) to select ultra night vision level 1/2/3. The ultra night vision function will be turned on automatically. The night vision image will be brighter at short distances (approx. 25yds and closer) when ultra night vision is activated.

Press controller (M) to enter display brightness menu . Rotating controller (M) selects display brightness between levels 1 ~ 6, and the display brightness adjustment function is activated automatically once the level is selected. The higher brightness level means brighter display image.

Press controller (M) to display color menu . Rotate controller (M) to select between the 5 color options: Daytime Color / Black & White / Green / White Phosphor / Amber, and the display color adjustment function will be changed.

Ultra Night Vision Mode tips:

1. In dark conditions where the infrared light needs to be turned off, turn on ultra night vision to the highest level 3 and display brightness to level 5 or 6, in order to get the best effect of ultra night vision mode. The ultra night vision is designed for dark conditions only and should not be activated in daylight. If you turn on the IR illuminator, the device will switch to ordinary night vision mode automatically and ultra night vision mode will be disengaged.
 2. Ultra night vision function must be activated manually each time you power the binocular, and it will not stay on after the binocular is turned off and then turned on again later.
-

Still Image (Photo) Capture

Press Photo/Video button (7) momentarily to take photo. The countdown timer has 4 options: Instant / Delay 3 seconds / Delay 5 seconds / Delay 10 seconds. You can select the option in the main menu: press Controller (M) for 2 seconds to enter main menu, scroll down to Settings, then select Photo Timer function and select desired countdown time option.

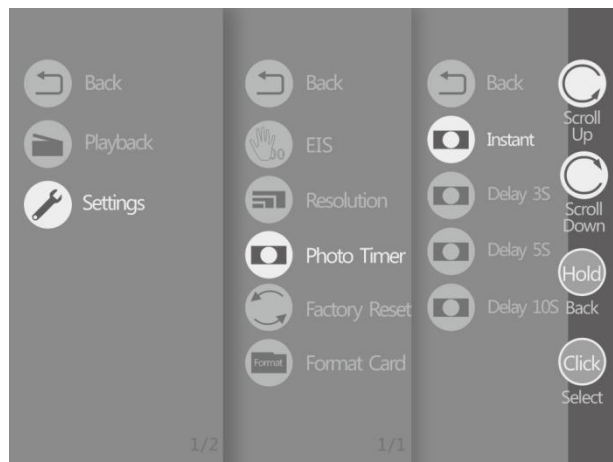

Video Recording / Video Resolution

Press and hold Photo/Video button (7) for 2 seconds to activate video recording. Press and hold the same button for 2 seconds again to stop recording video. There are four different resolution options for video recording: 4K / 2K / 1080P / 720P, which can be selected from the main menu. Press controller (M) for 2 seconds to enter the main menu, scroll down to Settings, then select Resolution option.

Video recording tips:

1. Pay attention to the distance focusing while video recording. Keep one hand near the distance focusing wheel (2) and you will be able to quickly adjust focus when necessary.
2. If you are recording moving objects, we strongly recommend using a quality tripod to minimize handshakes during recording.

During video recording you can take still image (photo) by pressing button (7) momentarily. A green camera icon will display on the top left corner, indicating the still image has been captured.

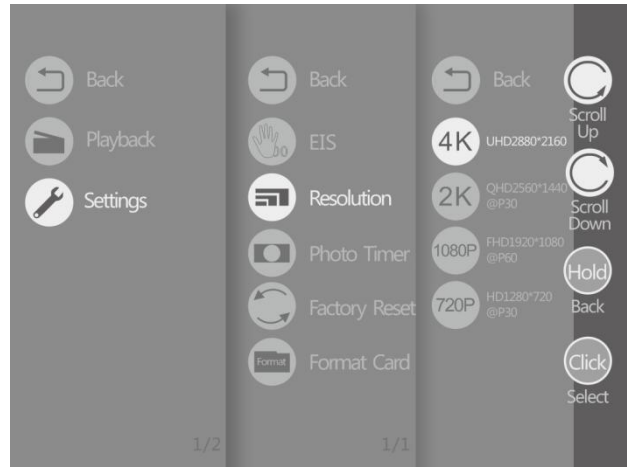

Laser Rangefinder Mode (Manual / Auto)

Press button (6) to measure distance once. The central icon box [] should be aimed at the object (at least 10m/11yds away).

Press the button (6) momentarily again and the distance data will be shown on the screen center. (Single measurement)

Press and hold button (6) for 2 seconds to activate auto rangefinder mode. The rangefinder will keep measuring distance constantly. (Scan)

Press and hold button (6) for 2 seconds to exit the rangefinder mode.



Rangefinder Tips:

1, It is normal to see a small bright line flashing on the display when using the rangefinder at night. This small line is the laser signal beam from the rangefinder, and the place where this small line reaches is the actual measurement point.

2, Because the laser rangefinder and objective lens are at different places, when users observe the near targets and distant targets, the small LRF line will appear at different positions on the display. This is normal.

3, The factory has calibrated the small LRF line and reticle before product delivery. But transportation vibrations may cause the small line and reticle to separate a little. This is also normal.

4, In poor atmospheric conditions, the device may fail to measure the distance, such as during rain or snow, fog, high humidity, smog, dusty environment, etc. During such conditions, you might only be able to measure distance of the near targets or targets with high reflection rate.

Wi-Fi function

1) On mobile phone, download and install the APP. **NOTE: APP information will be provided on a separate paper.** Then turn off the Wi-Fi on your mobile phone.

2) On the binoculars, press and hold the controller (M) for 2 seconds to enter the main menu, select Wi-Fi function and activate it. You will be able to see the following:

Wi-Fi Name: **M9-9803cf2185ac** (M9 is the Wi-Fi name, 9803cf2185ac is the serial number of Wi-Fi (every device has a unique serial number.)

Wi-Fi Password: **12345678** (12345678 is the factory default password. Once the device and mobile phone are connected, users can change the password on mobile phone via the APP.)



3) Now turn the Wi-Fi back on your mobile phone. On the WLAN menu of mobile phone, search for the device Wi-Fi name (in this example it is M9-9803cf2185ac) (reminder: every product has a unique serial number, so please check the binoculars screen for exact Wi-Fi name), and then click Connect, and type in the corresponding device Wi-Fi password 12345678 to connect. At this time, the mobile phone will display: Connected (no Internet access). If a mobile phone pops up a dialog box: The current WLAN is not available, do you want to continue using this WLAN? Or anything similar to that, you should select to use this WLAN at this time. Then exit the WLAN connection interface on the mobile phone.

4) On the mobile phone, click to open the installed APP. On the APP interface, click the icon in the middle of the screen. Now the mobile phone and device should connect successfully. After connection, the APP displays the real-time image of the device and enters the recording mode. To exit the APP connection, press and hold the controller "M" for 2 seconds on your device.

Note:

1. If the connection between the APP and the device is unsuccessful, please turn it off and restart the device to connect again.
 2. Device should be kept within 10m / 11yds within the mobile phone, in the open space for good connection, otherwise the signal may weaken, and the connection may not be reliable.
-

Electronic compass function

Press and hold the controller (M) for 2 seconds to enter the main menu. Scroll down to and select Electronic Compass function, then select On, short press controller (M) to activate the electronic compass function. Press and hold the controller (M) for 2 seconds to exit the main menu and the

display will show the calibration interface. Follow the calibration instructions. After calibration, the electronic compass will show product horizontal angle, elevation angle / depression angle, and 360° azimuth angle. When the device detects a weak signal during use, the calibration interface will appear on the display again. If this happens, follow the instructions to recalibrate.

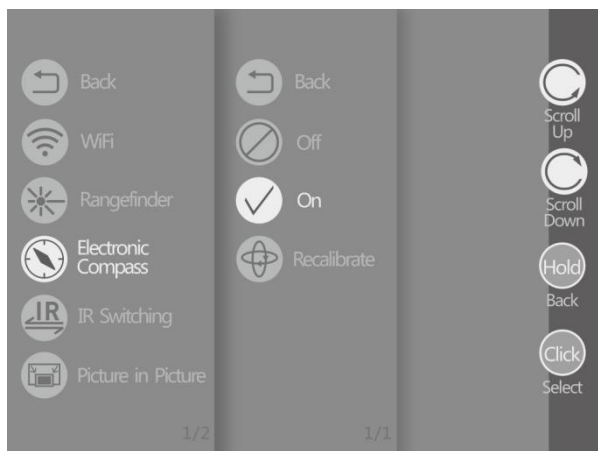

Picture-In-Picture

Press and hold the controller (M) for 2 seconds to enter the main menu, select Picture in Picture function. There are three options for picture in picture location within the display: Low Left / Low Middle / Low Right. When the picture in picture function is activated, it captures the center portion of the screen and that part of the displayed image will be slightly magnified and shown in the lower part of the image display, in the location of your choice.

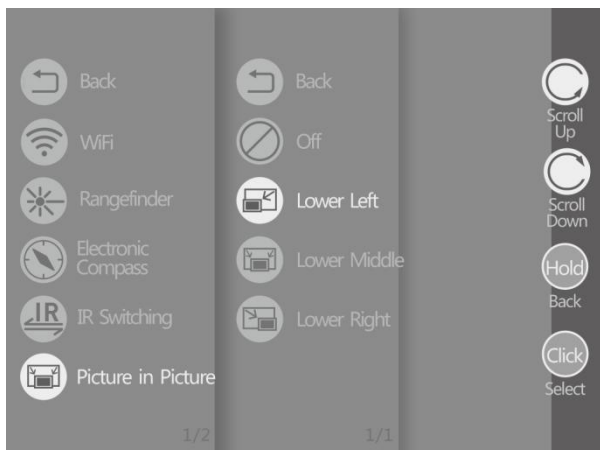

How to view photos and videos stored on the Micro-SD card

Press and hold the controller (M) for 2 seconds to enter the main menu, then scroll down and select Playback function. Select photo or video to view. Press controller (M) to play a video, press the controller (M) again to stop playing. Press and hold the controller (M) for 2 seconds to exit the Playback interface. You can also delete the playback files by pressing the Photo/Video button (7) while in the playback mode and then follow the prompts on screen with Controller (M) to delete the files.

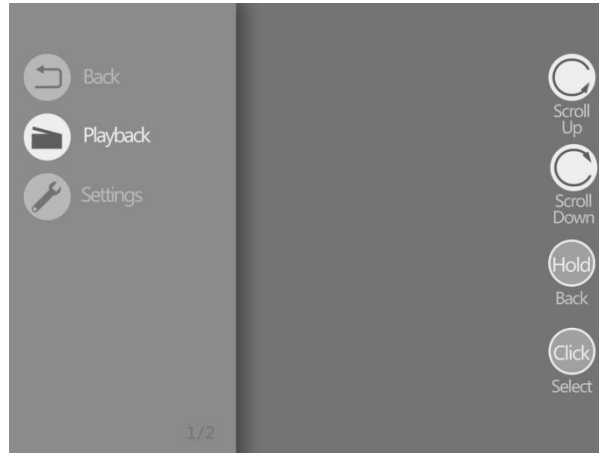

Electronic image stabilizer (EIS) mode

Press and hold the controller (M) for 2 seconds to enter the main menu, scroll down to Settings, then select EIS function, then select "On" and click Controller to activate it.

IMPORTANT: In EIS mode, the ability to change image magnification will be disabled.

During observation, the stabilizer icon is displayed on the bottom right of the screen. When the viewed image is unstable, the icon is green and flickers. It means the electronic image stabilizer function is actively working.

Due to the high magnification of this device, the EIS function only works effectively when there is a small tremble or shake effect. The effect of EIS is not significant when there is a significant shake.

To exit EIS mode, follow the same procedure as in activation and select "Off".



Factory reset

Press and hold the controller (M) for 2 seconds to enter the main menu, scroll down to Settings, then select Factory Reset function. Select OK to finish the factory reset. If a micro-SD card is inserted, files inside the card will not be deleted.

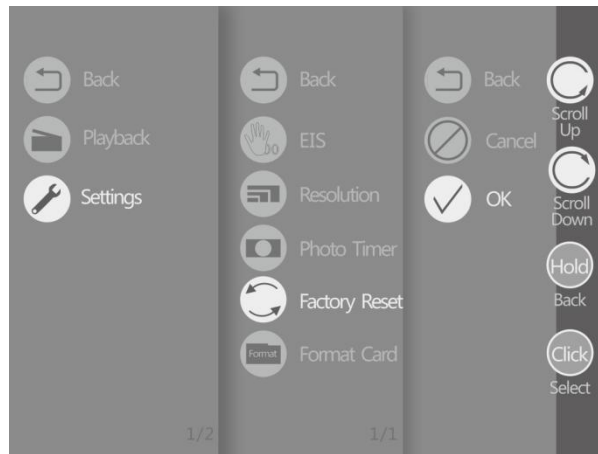

Formatting the Micro-SD card

Press and hold the controller (M) for 2 seconds to enter the main menu. Scroll down to Settings, then select Format Card function. Press controller (M), and a warning window will appear. Select OK to format the card.

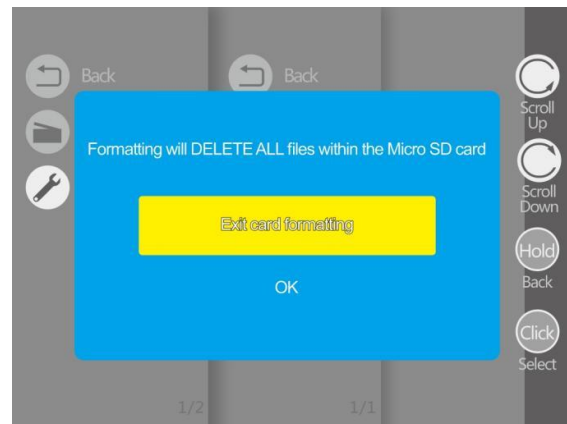
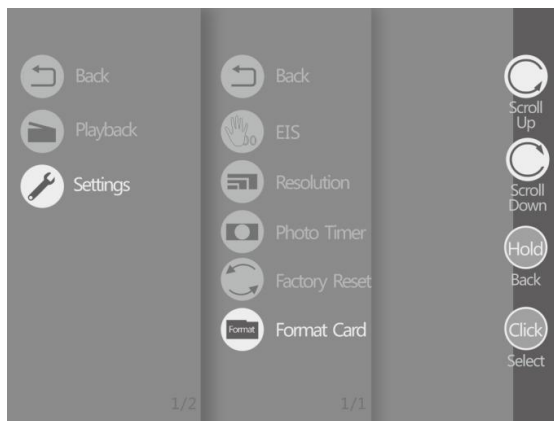

IMPORTANT:

All files inside the Micro-SD card will be deleted after formatting.

Auto Stand By / Auto Power Off / Indication Light Setting

Press and hold the controller (M) for 2 seconds to enter the main menu. Scroll down to Settings, then select either: Auto Stand By, Auto Power Off, or Indication Light. Auto Stand By function will turn the image display off after pre-selected time (5, 10 or 15min) to preserve battery life. Auto Power Off function will turn the power completely off after pre-selected time (15, 30 or 60min). Indication Light function can turn off the green power indicator light to prevent any light glare or to remain more covert during nighttime.

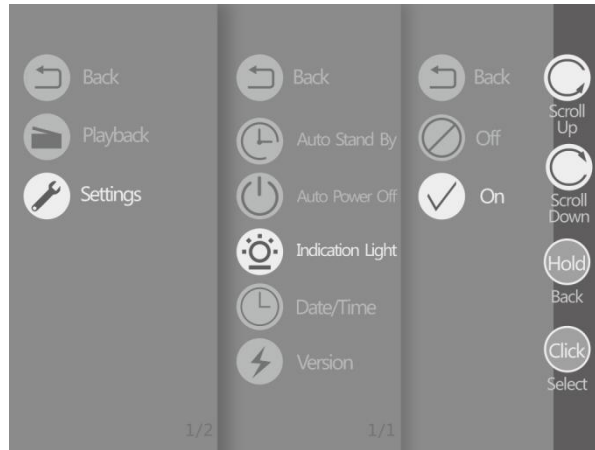
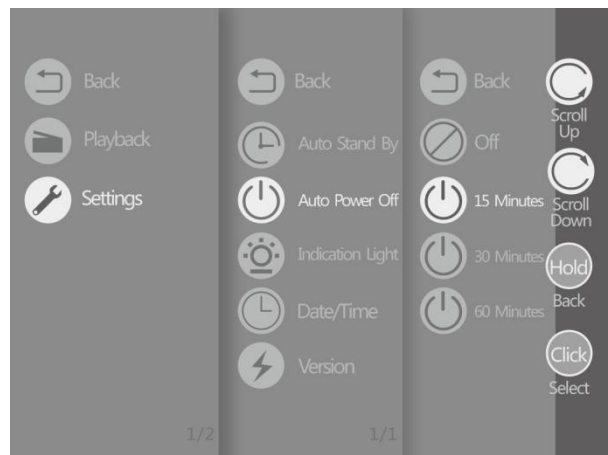

Setting and changing the Date/Time

Press and hold the controller (M) for 2 seconds to enter the main menu. Scroll down to Settings, then select Date/Time function.

Rotate the controller (M) to adjust data and press the controller (M) to switch among the fields.

After everything is confirmed, press and hold the controller (M) for 2 seconds to save the date and time and exit the menu screen.



Check the device software version

Press and hold the controller (M) for 2 seconds to enter the main menu. Scroll down to Settings, then select Version function. Users can check the device software version here.

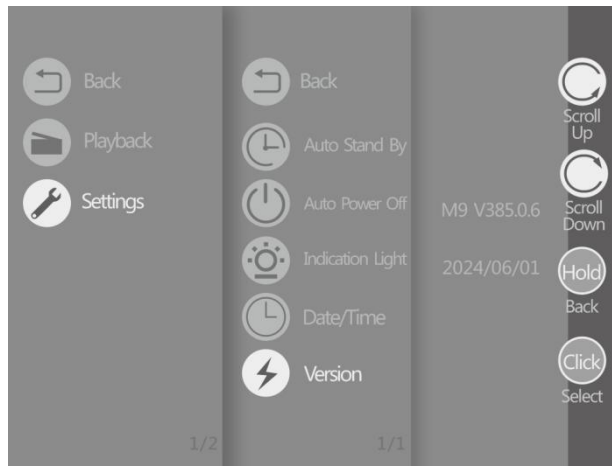

Changing the Language

Press and hold the controller (M) for 2 seconds to enter the main menu. Scroll down to Settings, then select Language function. There are up to 10 language options on 2 pages.



Connecting to an external Display / TV / Monitor

Through the HDMI output port (16) on the device, you can connect the binoculars to the external display via included HDMI cable. The external display must have an HDMI input port.

On the external display, set the corresponding signal input mode. After connecting and selecting the correct input, the external display will show the image from your digital day/night vision device.

Mounting the device onto the Tripod

Locate the tripod mount (18) on the bottom of the binoculars. It is a standard 1/4" thread size and it is compatible with most commercially available tripods. Mounting on the tripod is strongly recommended for long periods of observation and for situations where a steady hand is required, such as picture taking of birds or animals or when sky-watching.

Reformatting Micro-SD cards above 32GB to FAT32 format

Any micro-SD card above 32GB needs to be re-formatted from EXFAT format to FAT32 format, which is the format your device accepts. Please note that FAT32 is the most widely used format

and is also considered the most reliable format.

In order to re-format the card you must run it through a 3rd party provider. We suggest using Disk Partition. While nearly all of the providers would want you to buy their upgraded versions, you can just download their basic freeware version, and it would be sufficient to re-format the card. Disk Partition seems to be the most simple and hassle-free provider we could find:

<https://www.disk-partition.com/download.html>

- Download the “Standard Free” version and follow all the download instructions.
 - Once downloaded, open the program, and insert the micro-SD card into the computer.
 - Highlight the correct disc by single-click and then choose on the bottom left side of the menu to “Format Partition” (alternatively right-click on the highlighted disc and choose the same function). A pop-up window will appear. You can label your partition (such as “Luna Optics Binocular” or any other name you desire (it’s optional) and then make sure to select “FAT32” as the File System. Then click “OK”.
 - Once the format is finished, click on “Apply” located in the upper left corner. You must select “Apply” otherwise the formatting is not finished.
 - Your card is now formatted, but before you can use your 64-512GB card in our digital night vision product you must also format the card inside the product. To do so, insert the card into its slot (15), turn your binoculars on and through the menu find and select “Format”, then select “OK”. Once the card is formatted inside the night vision device it is now ready to use.
-

Technical Specifications:

Image Sensor:	-----Large Format, Quantum Elite, 120fps
Nighttime Sensitivity:	-----0.0005lux
Image Displays:	-----AMOLED 0.39” HD
Maximum Video Resolution:	-----2880 x 2160 (4K)
Still Camera Resolution:	-----5360 x 3008 (16.12MP)
Image Magnification:	-----6x (optical) - up to 36x (digital)
Objective Lens Specifications:	-----50mm (F0.9) Fast Light Transmitting
Field Of View:	-----10°
Interpupillary Distance:	-----60 – 71mm (adjustable)
Diopter Adjustment:	-----+/-6
Visual range (1/4 moon, IR on):	-----0.8m to 500m (building)
Visual range (Full Moon):	-----0.8m to 1500m (building)
Visual Range (Daytime):	-----0.8m to infinity
IR Illuminators:	-----850nm and 940nm, user selectable
Video Output:	-----1x HDMI (1080p)

USB Port:-----	1x USB-C
Tripod Mount:-----	Yes, ¼" size
Image Stabilizer:-----	Yes, Electronic
Electronic Compass:-----	Yes, With Angle Measurement
IR Filter / Color Enhancing Filter:-----	Yes, Internal, Automatic
Image Colors:-----	Natural (Full Color) / Black & White / Night Vision Green Phosphor / Night Vision White Phosphor / Amber
Wi-Fi:-----	Yes, Android / iOS
Micro-SD Card Capacity:-----	Up to 512GB (FAT32 format only)
Battery Type:-----	18650 (2pcs or 4pcs)
Operation Time:-----	Up to 8.5hrs (IR off, 20°C)
External Power:-----	5V/2A via USB-C
Working Temperature:-----	(-30°C~50°C) (-22F~122F)
Laser Rangefinder Distance Range (Building):-----	10m~1500m (11yds~1635yds)
Distance Measurement Precision:-----	(<400m +/-1m ... >400m +/-0.4%)
Laser Type:-----	905nm (Class-I Eye-Safe)
Dimensions:-----	205mm x 127mm x 70mm 8.1" x 5" x 2.8"
Weight:-----	0.88kg (1.94lbs)

Included in the package:

1. **LN-QE-B50** binocular
2. Deluxe carry/storage case
3. Padded neck strap
4. 18650 Battery charger
5. HDMI cable
6. USB cable
7. Micro-SD to USB Flash Adapter
8. 32GB Micro-SD card (installed in the card slot)
9. Cleaning cloth

NOTE: 18650 Batteries might not be included with this product due to transportation restrictions.

Luna Optics, Inc.

300 Hawthorn Dr. Fate, TX 75087 – USA

Tel: +1-972-722-1100 / E-mail: info@lunaoptics.com Web: www.lunaoptics.com

© 2024